

by HARMAN®

SYNTHESIS®

# JBL® SCL-3 JBL® SCL-4

In-Wall Loudspeakers

**OWNER'S AND INSTALLER'S  
MANUAL**

## CONTENTS

Introduction.....	2
Included.....	2
Speaker placement.....	3
Left and right speakers .....	3
Center channel speakers.....	3
Ambient surround speakers.....	4
5.1-channel systems.....	5
6.1-channel systems.....	5
7.1-channel systems.....	6
General installation notes.....	6
Connecting the speakers to the rest of your system.....	6
Rear enclosure installation .....	7
Front baffle assembly installation into back box.....	8
Specifications.....	10

## INTRODUCTION

**THANK YOU** for purchasing the JBL® SCL-3 and/or SCL-4 In-Wall loudspeakers. For more than 65 years, JBL engineers have been providing audio equipment for homes, concert halls, recording studios and movie theaters around the world, and JBL products have become the hands-down choice of leading recording artists and sound engineers. The SCL-3 and SCL-4 are the latest members of the JBL Synthesis Home Theater system. To get the best performance from your new loudspeakers, please read these instructions thoroughly.

## PACKAGE CONTENTS

### EACH JBL SCL-3 and SCL-4 PACKAGE CONTAINS:

- 1 – Loudspeaker
- 1 – JBL Logo set
- 2 – Center baffle screw (SCL-3 one screw is extra/spare due to special length)
- 13 – Baffle screws (SCL-4)
- 8 – Baffle screws (SCL-3)
- 1 – Set of 4 Security Plates (SCL-4 only). For SCL-3, security plates included with pre-construction wall bracket
- 1 – Grille
- 1 – User Manual
- 1 – Back Box with mounting brackets attached

If you suspect that there has been shipping damage, report it immediately to your dealer. We recommend that you keep the box and packing materials for future use.

## SPEAKER PLACEMENT

Positioning your loudspeakers properly is critical in order to achieve the sonic performance of a home theater. Please read the following section for guidance in correct and optimal placement.

### LEFT AND RIGHT SPEAKERS

If you have purchased a Synthesis home theater system, then the SCL-3 or SCL-4 models could serve as your front left and right main speakers. Since they have been designed for uniform coverage and maximum dispersion of sound, they should be placed with the center of the speakers at about the same height on screen as the actors would be, to aid in the illusion that the actors' voices are coming directly from their on-screen images. Ideally, the speakers will be placed about 60 degrees apart from each other, viewed from the listening position, so that the distance between the speakers is the same as each speaker's distance from the listener (Figure 1). Although their acoustic coverage area allows mounting the systems in any of the four possible orientations where necessary (horn located above, below, or to the sides of the woofers), the preferred orientation is with the horn above the woofer(s). This will depend greatly on mounting location height and room boundaries.

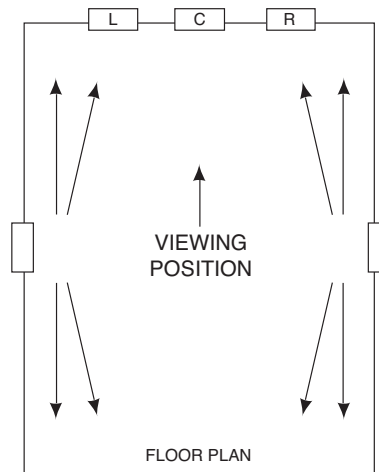

Figure 1

### CENTER CHANNEL SPEAKERS

SCL-4: If you have purchased the SCL-4 for the center position, be sure to place it vertically (horn above or below woofer) during installation in order to take advantage of its sound-dispersion characteristics. If you mount it horizontally, it will not provide the most optimized horizontal dispersion pattern. If the speaker is being used with a perforated projection screen, it should be mounted behind the center of the screen with the horizontal "center" axis aligned as close as possible to the center axis of the Left and Right channel speakers (See Figure 2).

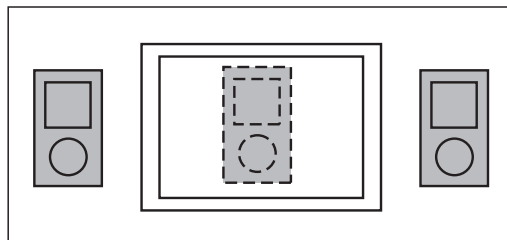

Figure 2

If a non-perforated projection screen, plasma display or other fixed video device is being used in the installation, the more compact alternative would be the SCL-3 model. Otherwise the SCL-4 could still be used in vertical orientation and mounted directly below and as close as possible to the video display (See Figure 3). In either situation however, the left and Right channel speakers may need to be lowered slightly to minimize the vertical positional difference. The inverse of this mounting method will also work (center channel located above the screen or video display).

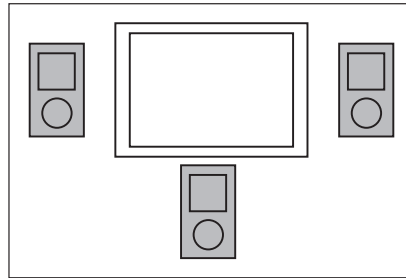

Figure 3

SCL-3: If you have purchased the compact SCL-3 model to use for the center channel speaker, be sure to position it vertically (horn above or below the woofers) during installation in order to take advantage of its sound-dispersion characteristics. If you mount it horizontally (horn to left or right of woofers), it will not provide the most optimized dispersion pattern. Similar to the SCL-4 center channel installation, the SCL-3 horizontal "center" axis should be aligned as close as possible to the center axis of the Left and Right channel speakers (See Figure 2).

If a non-perforated projection screen, plasma display or other fixed video device is being used in the installation, then the recommended location as described above is directly below and as close as possible to the video display (See Figure 3). Again, the inverse of this method will work also.

**NOTE:** It is extremely important to place the center, left and right speakers at the same height. The HDI horn containing the high frequency compression driver in the center channel speaker should be no more than 2 feet higher or lower than those in the left and right speakers. This preserves the "localization integrity" of "sound pans" in which the sound appears to move from left to center to right. If the program material also appears to travel up and down, it can destroy the illusion of panning effects and so should be avoided.

#### **AMBIENT SURROUND SPEAKERS**

Although it has been common for many years to use a number of surround speakers in commercial movie houses, until recently, the traditional home theater configuration called for 5.1 channels. The newer surround formats that are appearing in consumer audio equipment are calling for more complicated 6.1- and 7.1-channel systems now including height channel locations. The advantages of using additional speakers are many. Additional channels enable a more versatile use of directivity for a more accurate surround presentation. Also, a higher overall sound-pressure level can be achieved with less energy expenditure from any individual speaker. Placement of the surround speakers remains critical.

### 5.1-CHANNEL SYSTEMS

The SCL-3 and SCL-4 systems used for ambient surround speakers work optimally if they are placed no closer to the screen than the first row of viewing chairs. If there are two rows of chairs, these speakers should be placed between them. The ambient surround speakers should be placed higher than the seating area, at least 2 feet above (seated) ear level (Figure 6). The preferred method to mount the ambient surrounds is to put them directly in the side walls. This lets each speaker radiate to the front and back of the room and to reflect off the side walls. There are a few instances in which the ambient surrounds would perform better if mounted in the ceiling rather than the walls. If one or both of the walls are “acoustically dead,” due to the presence of openings, fabric, furniture or other absorption, it may be necessary to turn the ambient speakers sideways and, instead of mounting them in a vertical orientation, mount them with the horn toward the listening area.

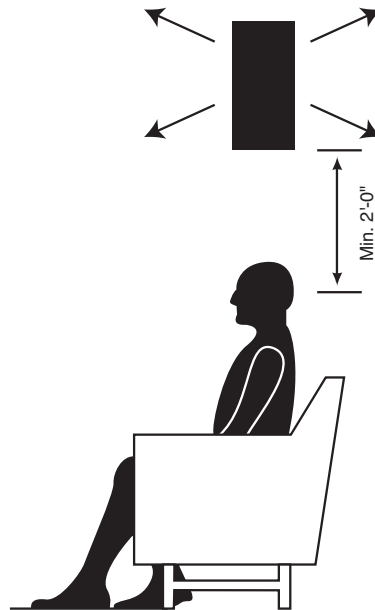

Figure 6

### 6.1-CHANNEL SYSTEMS

A 6.1-channel system can be thought of as a 5.1-channel system with the addition of a rear center speaker placed midway between the two surround speakers, and further to the rear than the surrounds. It should be placed at the same height as the side-surround speakers (Figure 7).

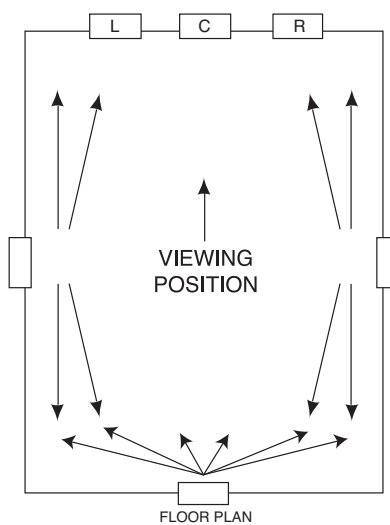

Figure 7

## 7.1-CHANNEL SYSTEMS

In a 7.1-channel system, two speakers are added for rear fill, in addition to the surround speakers in a 5.1-channel system. The two additional speakers are placed on the rear wall or near the rear wall in the ceiling (Figure 8).

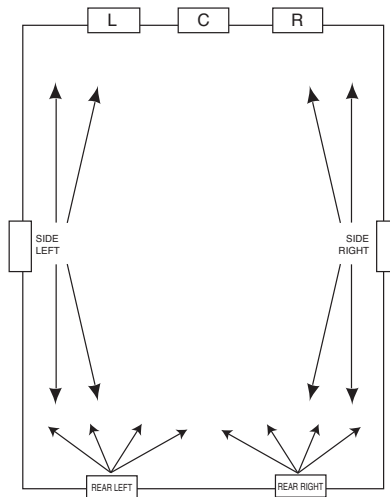

Figure 8

## GENERAL INSTALLATION NOTES

1. For best acoustic summation and smoothest frequency response at the listening position, align the center of horn to be on-axis or slightly above the listeners' ears.
2. Identify all wiring connections to rear enclosure and to baffle network.
3. Identify all wiring options (Bi-Wire, Bi-Amp, and Direct/Active).

## CONNECTING THE SPEAKERS TO THE REST OF YOUR SYSTEM

To connect the Synthesis SCL-3 and SCL-4 loudspeakers to the power amplifiers or receiver, use two-conductor insulated speaker wire. We recommend #14 AWG wire as a minimum size. Your JBL dealer can recommend the correct gauge for your application.

Both the SCL-3 and SCL-4 utilize spring-loaded binding posts that can accommodate up to #10 AWG stranded wire.

### PREPARING THE HOOK-UP WIRE

1. First determine the distance between your amplifier and the most distant speaker in each group (fronts, surrounds, back surrounds, passive subwoofers).
2. Now make the hookup wires for all speakers in each group this length, even if one speaker is much closer to your amplifier than the other. This will help maintain proper signal balance. Remember to make extra wires for bi-amp or bi-wire usage should this be selected.
3. Strip off 3/8" of insulation from both ends of each conductor.
4. Twist each set of stranded wires into a tightly bunched spiral. Run wires through walls to the mounting positions.
5. Speakers and electronics terminals have corresponding (+) and (-) terminals. Most manufacturers of speakers and electronics, including JBL, Inc., use red to denote the (+) terminal and black for the (-) terminal. Please confirm before connecting.

It is important to connect all speakers identically: (+) on the speaker to (+) on the amplifier and (-) on the speaker to (-) on the amplifier. Wiring "out of phase" (+ to - and - to +) results in thin sound, weak bass and poor imaging.

With multichannel surround sound systems, connecting all of the speakers in your system with the correct polarity remains equally important to preserve the proper ambience and frequency response of the program material.

Now find a visual difference between the two conductors of each molded pair of speaker wires. Differentiating marks can be a different color wire (copper or silver); a strand of yarn in one conductor; thin, raised ribs on one part of the outer insulation; or a printed marking on one part of the outer insulation. It doesn't matter which of the two strands go to the (+) and (-) on the speakers and amplifiers, as long as all speakers are connected identically. When attaching to the back box, push on the top of the spring-loaded post and insert the bare wire into the hole on the side.

## REAR ENCLOSURE INSTALLATION

### WARNINGS:

**DO NOT** exceed maximum forward position indicated on L-Brackets (Figure 9).

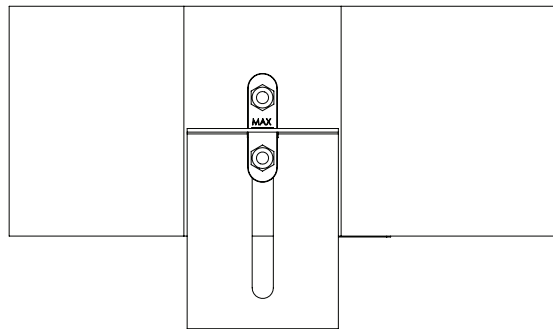

Figure 9

Supplied Security Plates **Must** Be Installed For All In-Ceiling Installations

For safety reasons, when retrofitting the new SCL-4 system into existing IN-CEILING installations, make sure to use the security plates supplied with the SCL-4 system.

Be sure to decide the correct orientation of your back box (Important Note on next page) before cutting into your wall or installing your Pre-Construction bracket!

### INSTALLATION STEPS:

1. Install wall bracket with included instructions (pre-construction brackets sold separately).
2. Remove wood panel shipping insert and metal cross brace where applicable. (Figure 10 and 11)

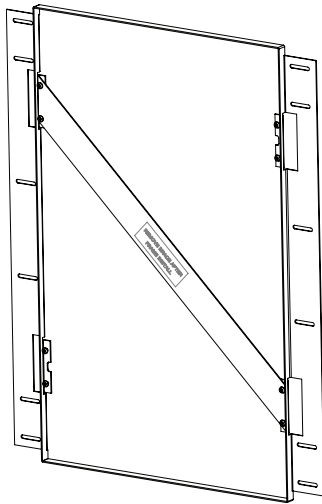

SCL-4 Pre-Construction Bracket

Figure 10

or

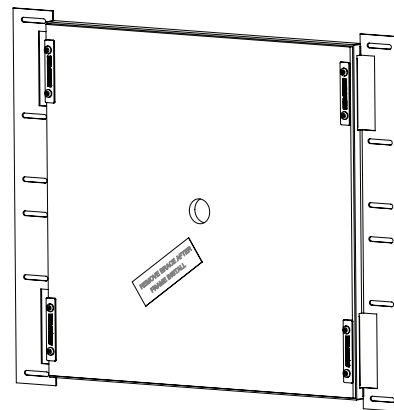

SCL-3 Pre-Construction Bracket

Figure 11

**IMPORTANT NOTE BEFORE INSERTING REAR ENCLOSURE:** On the SCL-4 systems, note that the terminal cup end of the back box is the “horn end” and the woofer end of the SCL speaker mounts away from the terminal cup end of the back box. So, the positioning of the rear enclosure terminal will determine the orientation of the horn. For example, if the terminal is located at the top then the horn will be located in the top position above the woofer. On the SCL-3 system, the system is designed so the orientation of rear enclosure terminals will not dictate horn location. The SCL-3 baffle (horn) can be positioned in any one of four positions despite installation orientation of rear enclosure.

3. Connect the wires from your amplifier (already run into wall) to the appropriate terminals on the terminal cup of the back box.
4. Position rear enclosure with the four L-brackets positioned against four tabs of wall bracket. Remember on SCL-4 systems, terminal orientation determines horn location. See “2” above.
5. Secure L-brackets to tabs with 8 supplied machine screws. (See Figure 12).

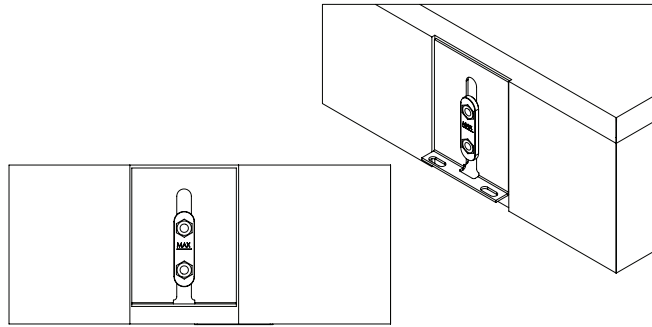

Figure 12

**WARNING:** Make sure to use the supplied Security Plates for all In-Ceiling installations!

6. Slightly loosen 8 large (1/4-20 x 3/4”) screws inside enclosure so that it moves in and out of wall.
7. Position front edge of enclosure to be flush to wall surface or any wall treatment. Tighten screws. For installations with very thick wall treatment, consider reversing the enclosure L-brackets so they stick out from the wall. This will offer additional forward placement of the system (See Figure 13)

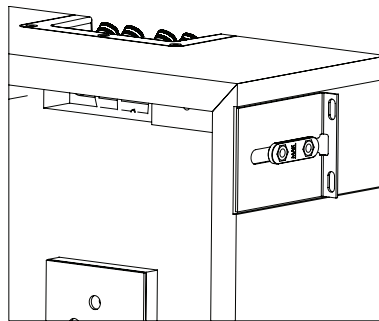

Figure 13

## FRONT BAFFLE ASSEMBLY INSTALLATION

### WARNINGS:

Do not over tighten baffle mounting screws! If using power tools to secure baffle screws, use only lowest clutch setting - enough to pull baffle to wall where gasket just touches mounting surface. For proper sealing of gasket and vibration isolation, hand tighten screws rest of the way to approximately 8 to 16 in-lbs maximum. (This is equivalent to approximately 1/2 - screw head rotation from when baffle gasket just touches enclosure and wall surface).

1. Make necessary electrical connections from rear enclosure terminal wiring to network by attaching the inline connector at the end of the wires to the header on the crossover printed circuit board. If you are bi-wiring or bi-amplifying your speaker, see Bi-Wiring and Bi-amplifying Instructions, below, before installing your speaker.
2. Remember to orient the SCL-4 so the horn installs close to the terminal cup (see note “b” under Rear Enclosure Installation, above). The SCL-3 can install in any orientation relative to its back box. This installation flexibility allows horn axis positioning and room acoustic optimization without the necessity of changing rear enclosure or wall bracket orientation.
3. Position Baffle assembly into enclosure. Gasket on baffle should be seated on enclosure edge and wall.

**CAUTION:** Make sure to carefully guide terminal connection wires when inserting the baffle to prevent pinching the wires during assembly (See Figure 13 and 14).



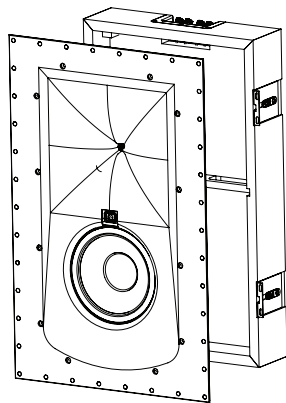

SCL-4 Flush-Mount Loudspeaker  
Figure 13

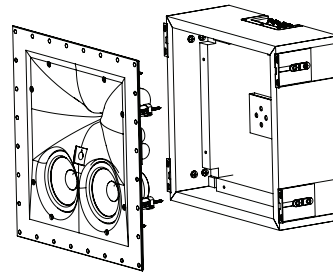

SCL-3 Flush-Mount Loudspeaker  
Figure 14

or

4. Start with tightening the center mounting screw. This can be used to hold the baffle assembly into the back box.
5. Secure perimeter baffle mounting screws and tighten (See WARNINGS concerning over tightening screws!).
6. Insert rubber logo base into designated area on top of the center mounting screw.
7. Remove JBL Logo adhesive back and insert Logo into rubber base with proper orientation.
8. Insert zero-bezel metal grill onto baffle. Magnets on the baffle will secure grill. Be sure the grille sits down to the wall all the way around; a grille sitting up on the baffle could fall off during operation (See Figure 15 and 16).

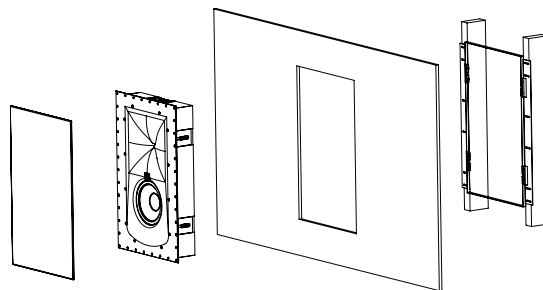

SCL-4 Flush-Mount Loudspeaker  
Figure 15

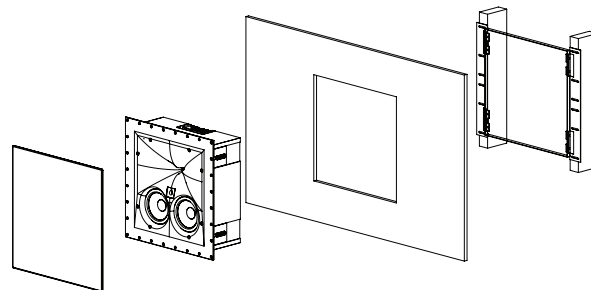

SCL-3 Flush-Mount Loudspeaker  
Figure 16

## BI-WIRING AND BI-AMPING

The bi-wire or bi-amp option is easy to set.

1. Make the choice to bi-amp or bi-wire, and cut two pair of wires for each bi-wired speaker.
2. Mark both ends of the wire pairs being used for the purpose, and then run the two sets of wire to the mounting position.
3. Connect one + and - pair to the "HF" input, the other to the "LF" input.
4. Before installing the speaker that will be bi-wired or bi-amplified, remove the two blue jumpers (Bi-amp Jumper Hot and Bi-amp Jumper Ground). Do this by squeezing the connectors for the jumpers just below where the wire is crimped to the connector. This should release the connector lock. If this doesn't work, slide the plastic boot back onto the wire and depress the lever for the lock with a ballpoint pen or small tool while pulling gently on the wire.
5. Proceed to install the speaker normally following the instructions above.

## SPECIFICATIONS

SPECIFICATIONS	SCL-3	SCL-4
Speaker Type:	2-way Flush-Mount Loudspeaker	2-way Flush-Mount Loudspeaker
Low Frequency Transducer:	Dual 5.25" (130mm) cast-frame, Advanced Aluminum Matrix cone woofers	7" (180mm) cast-frame, Advanced Aluminum Matrix cone woofer
Mid/High Frequency Transducer:	1" (25mm) 2409H annular ring diaphragm polymer compression driver	1" (25mm) 2409H annular ring diaphragm polymer compression driver
Maximum Recommended Amplifier Power:	300watts RMS	300watts RMS
Frequency Response (-6dB on-axis):	65Hz - 33kHz	45Hz - 33kHz
Coverage Area(-6dB @ 20KHz):	90 x 60 Degrees (Hor x Vert)	100 x 100 Degrees (Hor x Vert)
Coverage Area (-6dB @10KHz):	110 x 90 Degrees (Hor x Vert)	120 x 120 Degrees (Hor x Vert)
Sensitivity (2.83V@1m):	91dB	91dB
Nominal Impedance:	6 Ohm	6 Ohm
Crossover Frequency:	1.3 kHz	1.3 kHz
Enclosure type:	Sealed back box	Sealed back box
Inputs:	Dual sets of Gold-plated Binding Posts	Dual sets of Gold-plated Binding Posts
Dimensions (including grille and back box) (H x W x D)	16.5" x 16.5" x 6" (418mm x 418mm x 153mm)	25.4" x 16.47" x 4" (644mm x 418mm x 102mm)
Weight:	25.4 lb (11.5 kg)	28.2 lb (12.8 kg)
Finishes:	Matte Black with Paintable White Grille	Matte Black with Paintable White Grille

Please visit [JBLSYNTHESIS.COM](http://JBLSYNTHESIS.COM) for additional language support on the user manual.

Veuillez visiter [JBLSYNTHESIS.COM](http://JBLSYNTHESIS.COM) pour obtenir le mode d'emploi en d'autres langues.

Para obter o manual do usuário em outros idiomas, acesse [JBLSYNTHESIS.COM](http://JBLSYNTHESIS.COM)

Ga naar [JBLSYNTHESIS.COM](http://JBLSYNTHESIS.COM) voor de handleiding in andere talen.

Gå til [JBLSYNTHESIS.COM](http://JBLSYNTHESIS.COM) for bruksanvisning på flere språk.

Если вам требуется дополнительные версии руководства пользователя на других языках, посетите сайт [JBLSYNTHESIS.COM](http://JBLSYNTHESIS.COM).

別の言語に対応したユーザーマニュアルを読むには、[JBLSYNTHESIS.COM](http://JBLSYNTHESIS.COM)にアクセスしてください。

사용자 설명서에 대한 추가 언어 지원은 [JBLSYNTHESIS.COM](http://JBLSYNTHESIS.COM)에서 확인하십시오

请访问 [JBLSYNTHESIS.COM](http://JBLSYNTHESIS.COM) 以获取其他语言版本的用户手册。

Visita [JBLSYNTHESIS.COM](http://JBLSYNTHESIS.COM) para obtener el manual de usuario de soporte en idiomas adicionales.

Weitere Sprachfassungen der Bedienungsanleitung findest Du unter [JBLSYNTHESIS.COM](http://JBLSYNTHESIS.COM).

Si prega di visitare [JBLSYNTHESIS.COM](http://JBLSYNTHESIS.COM) per i manuali di istruzioni in altre lingue.

Jos tarvitset ylimääräistä kieleen liittyvää tukea käyttöohjeesta, käy osoitteessa [JBLSYNTHESIS.COM](http://JBLSYNTHESIS.COM).

Gå ind på [JBLSYNTHESIS.COM](http://JBLSYNTHESIS.COM) for at se betjeningsvejledningen på flere sprog.

Gå till [JBLSYNTHESIS.COM](http://JBLSYNTHESIS.COM) för mer information om språk i användarmanualen.

Торговая марка:	JBL
Назначение товара:	Пассивная акустическая система
Изготовитель:	Харман Интернешнл Индастриз Инкорпорейтед, США, 06901 Коннектикут, г.Стэмфорд, Атлантик Стрит 400, офис 1500
Страна происхождения:	Мексика
Импортер в Россию:	ООО Внешторг-Юг, Россия, 171640, Тверская область, г.Кашин, ул. Карла Маркса, д.57А
Гарантийный период:	1 год
Информация о сервисных центрах:	<a href="http://absolut-audio.ru/Servis/">http://absolut-audio.ru/Servis/</a> тел. +7 (495) 995-10-80
Срок службы:	5 лет
Срок хранения:	не ограничен
Условия хранения:	Стандартные при нормальных значениях климатических факторов внешней среды
Номер документа соответствия:	Товар не подлежит обязательной сертификации
Дата производства:	Дата изготовления устройства определяется по двум буквенным обозначениям из второй группы символов серийного номера изделия, следующих после разделительного знака «-». Кодировка соответствует порядку букв латинского алфавита, начиная с января 2010 года: 000000-MY0000000, где «M» - месяц производства (А - январь, В - февраль, С - март и т.д.) и «Y» - год производства (А - 2010, В - 2011, С - 2012 и т.д.).



HARMAN International, Incorporated  
8500 Balboa Boulevard, Northridge, CA 91329 USA

[www.jblsynthesis.com](http://www.jblsynthesis.com)

© 2016 HARMAN International Industries, Incorporated. All rights reserved.

JBL, Differential Drive and HDI are trademarks of HARMAN International Industries, Incorporated, registered in the United States and/or other countries.

Features, specifications and appearance are subject to change without notice.